



Flow
waterjet

HUSKY® 55,000 psi Pump with External Compensation

Flow's 55,000 psi Waterjet Pump Raises the Bar in Productivity and Reliability



Benefits

- Maximum productivity from 55,000 psi — the highest pressure available in the industry
- Lower cost of operation gives contractors a competitive advantage when bidding on jobs
- Compatible with all existing Flow surface preparation products
- Latest technology makes 55,000 psi pump the easiest-to-use, most reliable pump in the industry

Standard Features

- 290 hp Caterpillar engine, producing 210 nhp— the highest available nozzle horsepower
- Automated settings for multiple tool operation
- Diagnostic sensors to assist with troubleshooting and preventative maintenance
- Caterpillar® C-9 Engine that meets worldwide Tier 2 emission standards
- On-board water booster and filtration system
- Full pressure compensation allows for multiple tool use
- Triple high-pressure outlet ports
- 82 gallon fuel tank
- Multilingual remote operator box
- Small 58.5" x 102" footprint

Maximum Productivity, Lower Cost of Operation

Maximum productivity and low operational costs are the keys to keeping your business competitive. Flow's 55,000 psi HUSKY pump sets a new industry standard for both productivity and reliability, giving you a portable ultrahigh-pressure waterjet pump that contributes to your bottom line by allowing you to work more efficiently and take on more jobs. The HUSKY is the world's first 55,000 psi direct drive triplex pump with full pressure compensation giving you the power you need to reduce your operating costs and increase productivity on a square foot basis. Now you get Flow's proven HUSKY UHP pump with a world class Caterpillar C-9 engine that meets Tier II emission requirements, on board diagnostics and lower fuel consumption.

The 55,000 psi HUSKY is compatible with all other Flow machines, meaning no additional investment in technology is necessary to upgrade.

Innovative Technology Helps You Work Smarter, Faster

Built around Flow's existing technology, which has seen millions of operating hours worldwide, Flow enhanced its 55,000 psi HUSKY with innovative technological features making its operation and maintenance easier than ever before.

The pump's Operator Control System allows the user to work remotely without having to attend to the machine, while your operators focus on other tasks. The Husky pump performs system troubleshooting by monitoring for inlet water pressure, high engine or pump temperatures, and low engine or pump oil pressure, and will automatically shut down the system should a situation arise and automatically relieves system water pressure to 0 psi within a second of shutdown.

The HUSKY pump is also equipped with diagnostic sensors that assist with troubleshooting and preventative maintenance. These sensors check for and alert the operator of any problems that may arise. The result: lower operating costs and increased up-time.

Specifications

- Operating Pressure: 55,000 psi (3,790 bar)
- Maximum Flow Rate: 6.5 gpm (24.5 lpm)
- Approximate Weight: 5575 lbs (2534 kg) dry
- Fuel Capacity: 82 gal (310 l)
- Engine: 290 hp (216 kW) Caterpillar C-9
- Nozzle Horsepower: 210 nhp (157 kW) continuous duty
- Speed: 2,100 rpm continuous duty
- Water Filtration: 10 micron absolute
- Mounting Type: Skid or optional trailer mount

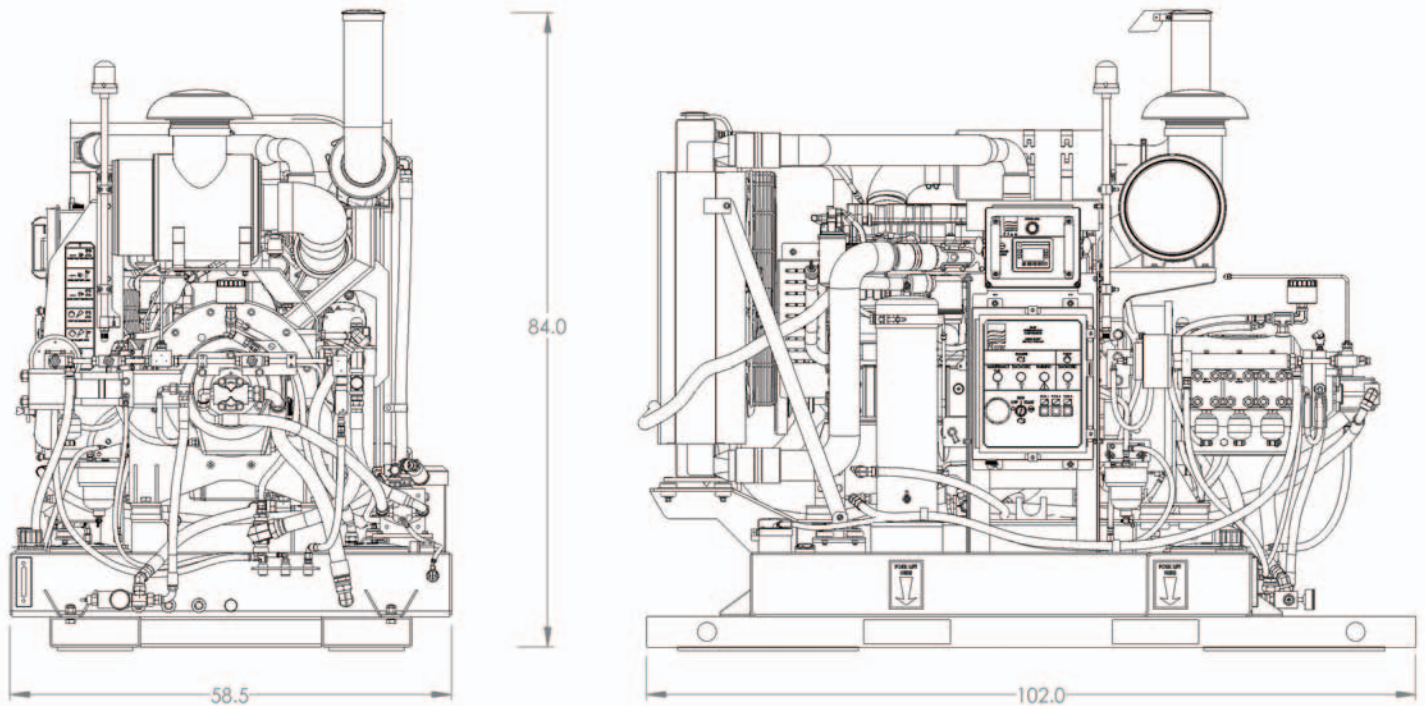

Flow International Corporation is the world's leading developer and total system solutions for industries including automotive, aerospace, job shop, paper, surface preparation, and food production. Regional Sales Representatives and manufacturing facilities are located throughout the United States and Canada. International Distributors and Agents are located worldwide. Call 253-850-3500, toll-free 800-446-FLOW, for the representative nearest you.

United States, Canada, & Mexico

Flow International Corporation World Headquarters • 23500 64th Avenue South • Kent, Washington 98032 USA
Tel: 253-850-3500 • Toll-Free: 800-446-FLOW • Fax: 253-813-9733 • info@flowcorp.com • www.flowcorp.com

Central America, South America, & Caribbean

Flow Latino • Rua do Curtume, 694 – Lapa • São Paulo, SP 05065-001 Brazil
Tel: +55-11-3611-2822 • Fax: +55-11-3611-3322 • flowlatino@flowlatino.com • www.flowlatino.com

Europe, Middle East, & Africa

Flow Europe GmbH • Gewerbestrasse 95 • D-75015 Bretten Germany
Tel: +49-7252-538-0 • Fax: +49-7252-538-530 • marketing@flowgmbh.com • www.flowgmbh.com

Asia, Australia, New Zealand, Korea, & China

Flow Asia • 1F, No. 5, Technology Road • Science-based Industrial Park • Hsin chu, 300 Taiwan
Tel: +886-3-577-2102 • Fax: +886-3-577-3070 • sales@flowasia.com • www.flowasia.com

Japan

Flow Japan • Level 18 Yebisu Garden Place Tower • 4-20-3 Ebisu, Shibuya-ku Tokyo 150-6018 Japan
Tel: +81-3-5789-5920 • Fax: +81-3-5789-5919 • fjc@flowjapan.co.jp • www.flowjapan.co.jp



Flow
waterjet